

# X-Head\_LC

# Installation Guide

06. 01. 2020

908. 652. 6779 x 4

[sales@machineartmoto.com](mailto:sales@machineartmoto.com)

- Parts:** Left & Right Guards  
 Left & Right Rubber Liners  
 2-T25 x 20 mm Torx screws  
 (re-use 2 existing Torx screws)  
 2- T50 Long Torx bolts

- Tools** T25 Torx screw driver  
**Required:** T50 Torx socket wrench  
 Small Torque wrench

**A torque wrench is essential!**

Most installation problems involve oil leaks or bolt breakage because of over tightening. Use a **small torque wrench** set in Newton Meters or Inch/Pounds. Or, take the bike to a qualified BMW technician for installation.

- \* **BEFORE BEGINNING WORK, READ THESE INSTRUCTIONS FROM START TO FINISH.**
- \* **PLACE BIKE ON CENTER STAND ON LEVEL GROUND.**
- \* **ALLOW ENGINE TO COOL BEFORE STARTING INSTALLATION**
- \* **AFTER THE FIRST RIDE, RE-CHECK FASTENER TIGHTNESS.**



**1** Remove one T25 Torx screw retaining the spark plug cover. *This screw will be re-used.*  
 Remove spark plug cover.



**2** Unscrew rear valve cover bolt with a T50 Torx socket wrench. Pull out the bolt, cup washer, & rubber seal. *You may feel resistance. Washer & rubber seal will be re-used.*

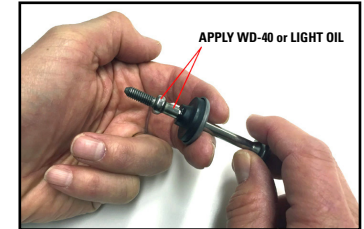

**3** Apply light oil to the shaft of the bolt just removed. Placing two fingers behind the cup washer, gently pull off the rubber seal.

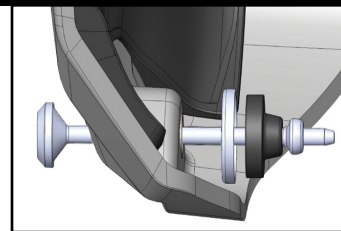
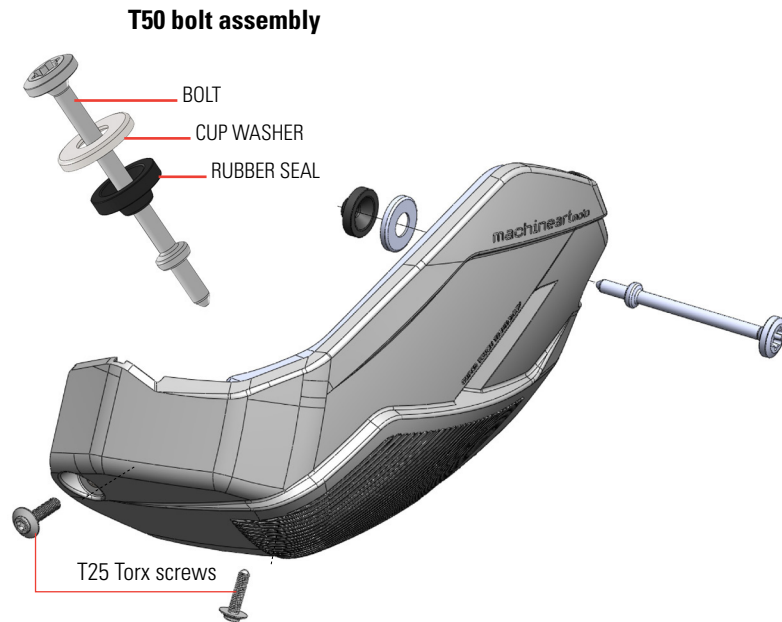

**4** Insert NEW T50 Long Bolt through hole in X-Head. Place cup washer over the Bolt with flat side against inside of X-Head. Apply light oil over the ball & shaft & gently push rubber seal over the ball as shown.



**5** Place X-Head into position. With your fingers, start turning the Bolt until it engages the thread. *This may take a few tries.* Keep it finger tight, for now.



**6** Fasten the front of X-Head with the T25 Torx screw previously removed. *Do not yet tighten!*



**7** Fasten the bottom of X-Head with the new T25 Torx screw provided. *It is difficult to see the thread on the underside of the engine, so be careful not to cross-thread the screw.*



**8** Tighten the T50 Bolt with a T50 socket and a **small torque wrench**: Torque: **10 Nm; Newton/meters or 88 in/lb. that's inch/pounds.** *A little less is better than too much!* **DO NOT OVER TIGHTEN!**

**NOTE:**  
 A light film of oil may appear at the bottom of the valve cover after removing the T50 Bolt. Carefully wipe it off before re-installing the bolt and finishing the installation.

**Care Instructions:**  
 Dirt will accumulate around X-Heads during use. Periodically remove them to clean the engine, typically at service intervals. Any rubber residue can be cleaned with fine polishing compound.

WARNING AND DISCLAIMER: All parts manufactured, designed or sold by Machineart Moto("MaMo") should be installed by a qualified BMW motorcycle technician. The risk of injury or component damage is increased by improper installation or misuse of equipment. MaMo's customers must exercise good judgment in the use, control, alteration, part selection and installation, and maintenance of their motorcycles. In the event of a possible defect in material or design, or any other defect in a part manufactured, designed or sold by MaMo, the responsibility of MaMo is limited to a refund of the purchase price or the replacement of the part if MaMo determines the part to be defective, and subject to MaMo's inspection of the part within thirty (30) days from the date of purchase. (Note: any attempted repairs or modifications made to MaMo products will void this limited warranty). MaMo, under no circumstances will be responsible for incidental and/or consequential damages, property damage, personal injury damage, or damage, injury, cost or expense of any kind or nature whatsoever except as provided by law. MaMo makes no other warranty, express or implied, including without limitation any warranties of merchantability and fitness for a particular purpose.